



Installation Instructions

Application Fits
2015 MINI Countryman
X7335

1.25" EcoHitch Stealth

200 lb. Tongue Weight/ 2,000 lb. Towing Weight

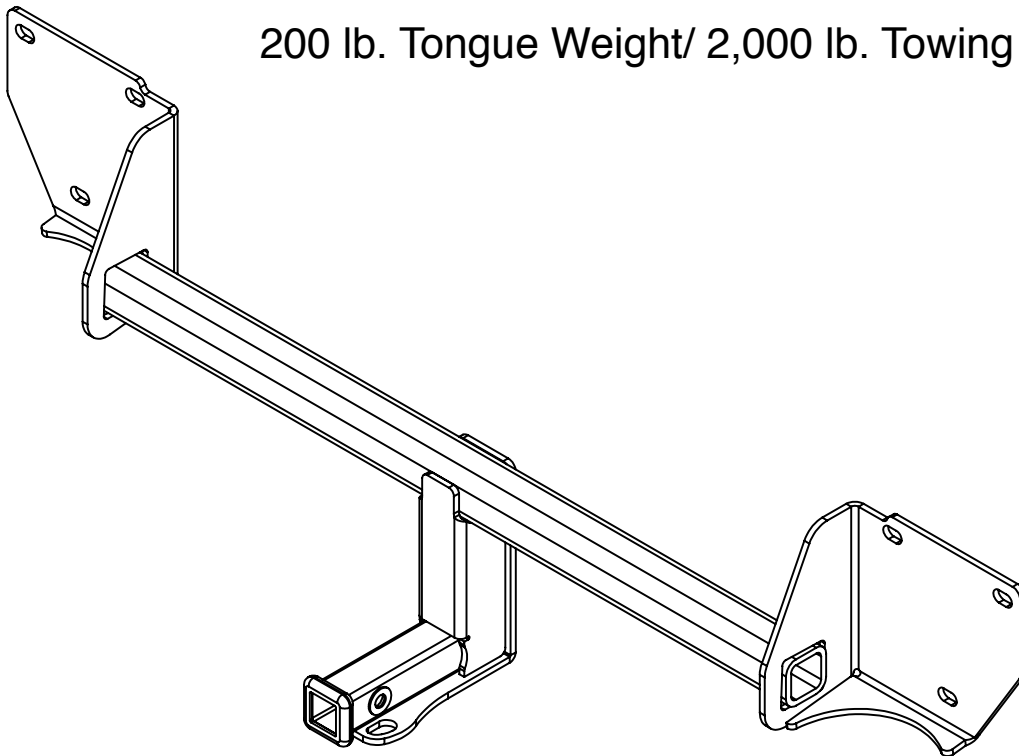

Torklift Central
315 Central Ave N
Kent, WA 98032
253-854-1832
www.torkliftcentral.com
support@tlcentral.com

Stay Connected



Bolt Kit Weight: 601g +/-

Hardware Included

QTY Fastener

6 M10-1.50 Serrate Flange Nut

1 12" Trim-Lok

READ THESE INSTRUCTIONS THOROUGHLY AND ACCOUNT FOR ALL HARDWARE LISTED BEFORE BEGINNING INSTALLATION!

Step 1. Raise vehicle on suitable jack stands, ramps, or hoist.

Step 2. Lower the exhaust by disconnecting the rubber exhaust bungs. Use a silicon based lubricant to ease removal. Do not let the exhaust hang freely, support with a stand, wood block, or other prop. See Figure [1] & [2].

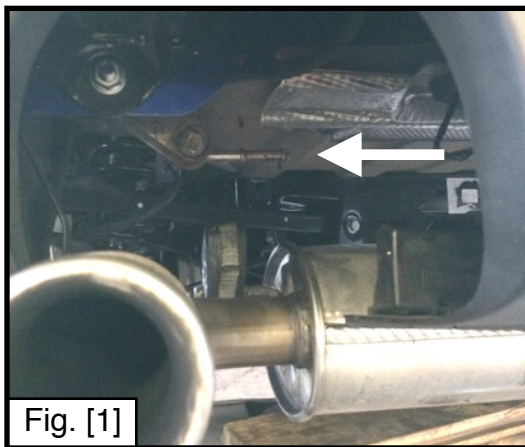

Fig. [1]

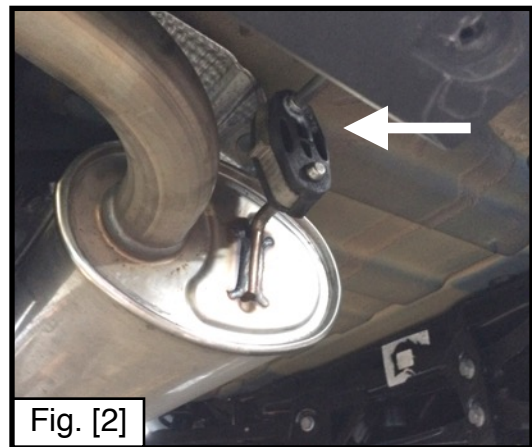

Fig. [2]

Step 3. Remove (2) lag screws & (3) push-pin fasteners from each of the rear wheel wells. Peel back the wheel well liner near the top of the well where the bumper meets the side body panels. Here you will find (1) screw on the driver and passenger sides to remove and a wire harness to disconnect. See Figure [3], [4], [5].

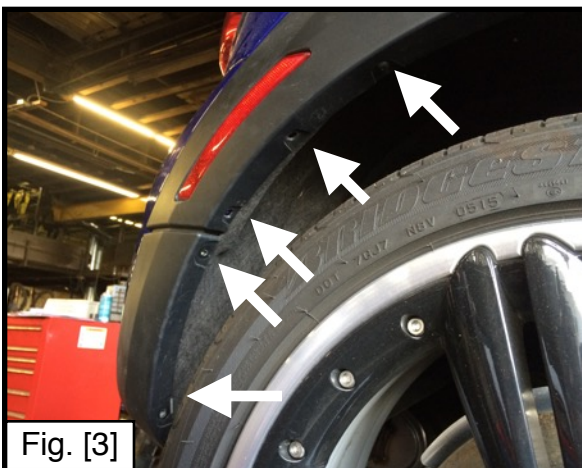

Fig. [3]

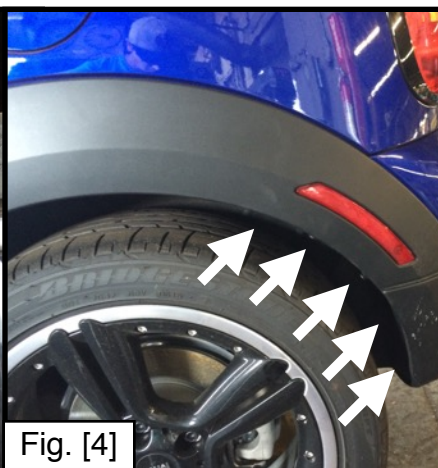

Fig. [4]

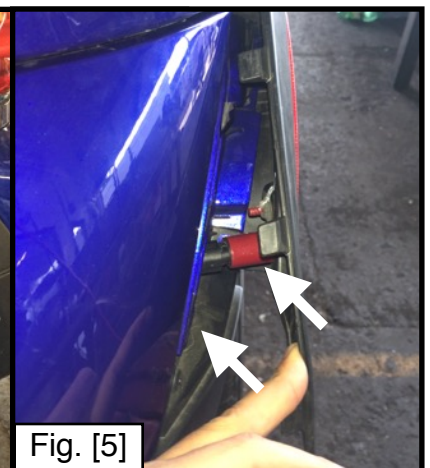

Fig. [5]

Step 4. Open the lift gate and remove (2) fasteners located along the lip of the trunk area. See Figure [6].



Step 5. Located on the underside of the bumper, remove (2) fasteners from two hangers located off center and just above the muffler. See Figure [7].



Step 6. With all fasteners removed, begin peeling the bumper away from the vehicle starting at the wheel wells and working toward the center. It may be helpful to have an assistant during this step to avoid damaging the bumper fascia. As you remove the bumper fascia, disconnect a number of sensor and light wire harness connections. See Figure [8].



Step 7. With the bumper fascia removed and the wire harness moved out of the way, remove the impact bar and set aside. Place the EcoHitch onto the impact bar stud bolts of the vehicle then replace the impact bar over the frame plates of the EcoHitch on the stud bolts. Secure with the (6) provided M10 fasteners and hand tighten. Once the hitch is centered on the vehicle, torque the M10 hardware to 38ft-lbs.

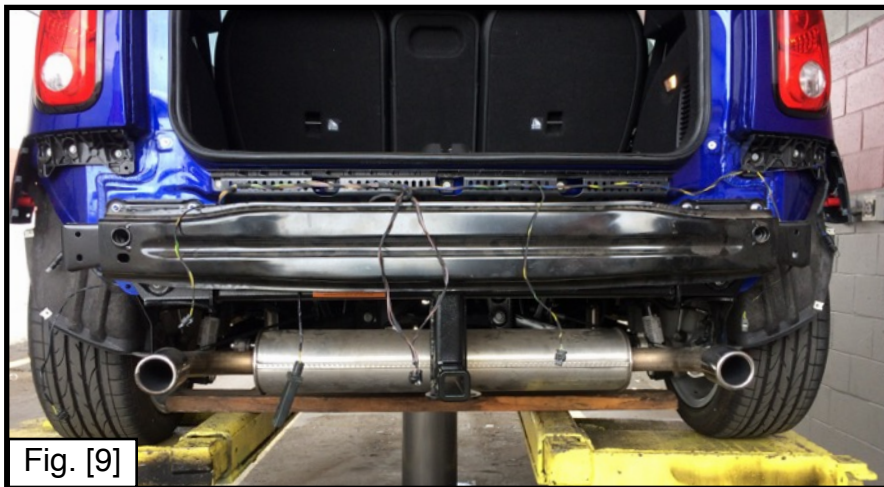

Step 8. Mark and trim a 3" x 4-3/4" section from the bumper fascia then apply the Trim-Lok to the cut edge and trim excess. See Figure [10].

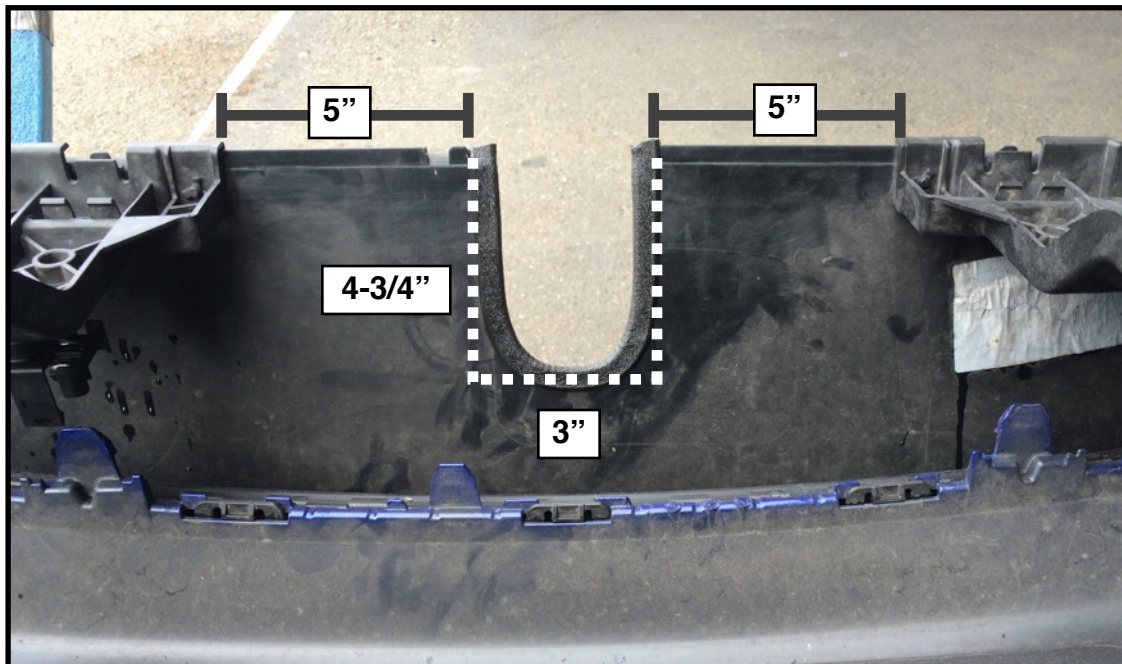

Step 9. Reinstall the bumper fascia and exhaust by following these instructions in reverse starting at Step 6.

Congratulations on the completed installation of the MINI Countryman Stealth EcoHitch! It is designed with a lifetime warranty for a lifetime of enjoyment. If you have any questions or suggestions please contact our tech support at support@tlcentral.com or by phone at (253) 854-1832.



WARRANTY/DISCLAIMER INFORMATION

Torklift Central requires proof of purchase for warranty claim registration, with pictures of any defective product before issuing a replacement. Torklift will not accept claims on any product without proof of purchase, which can be faxed, scanned, emailed or mailed to the information provided below. Torklift Central warrants its hitches, custom hitch receivers and accessories (excluding electrical wire harnesses which carry a warranty from their specified manufacturer) from date of purchase against defects in material and workmanship under normal use and service for the ownership life of the original consumer purchaser. Torklift Central will replace free of charge any part that proves defective in material or workmanship when presented to Torklift Central, transportation charges prepaid by purchaser, at the address below. **This warranty is limited to defective parts replacement only. Labor charges and/or damage incurred in installation or replacement, as well as incidental and consequential damages connected therewith are excluded.** This warranty does not include normal wear and tear or the finish and paint. Rusting, cracking or peeling of the finish is also excluded. Some states do not allow the exclusion or limitation of incidental or consequential damages, so the above limitation or exclusion may not apply to you. Any damage to Torklift Central products as a result of misuse, abuse, neglect, accident, improper installation or any use violative of instructions furnished by Torklift Central will void the warranty. This warranty gives you specific legal rights and you may also have rights, which vary from state to state. With warranty service, you may be able to go to a small claims court, a state court or a federal district court.

Although Torklift Central trailer hitches are both tested and rated for towing within the specific capacity label found on each trailer hitch. Torklift Central assumes no liability for vehicle manufacturers warranty due to the use of a Torklift Central trailer hitch being used for towing behind any vehicle or using the trailer hitch in a manner that it was not designed for. Although this specific trailer hitch has a load rating, which includes trailer tongue weight, and a trailer weight carrying capacity, Torklift Central is not responsible for the voiding of any warranty on any vehicle due to factory towing limitations. All vehicle warranties are the sole property and responsibility of the owner of the vehicle that the Torklift Central trailer hitch is installed upon. Torklift Central does not endorse towing behind any vehicle if the vehicles manufacturer states that towing is not recommended. Check your vehicle's owner's manual for the proper tow rating of your vehicle.

ADDRESS: 315 Central Ave N. Kent, WA 98032

WARNING Your vehicle may have a lower tow rating than this trailer hitch. If your vehicle's tow rating is less than the rated towing capacity on your Torklift Central trailer hitch, your trailer hitch capacity is limited to your vehicle's factory rated towing capacity.

FOR EXAMPLE: the label on your Torklift Central trailer hitch states it's capacity is rated for 500 pounds tongue weight and 5,000 pounds towing weight. However your vehicle's factory rated towing capacity is limited to only 350 pounds tongue weight and 3,500 pounds towing weight. In this example your maximum towing capacity of your Torklift Central trailer hitch is limited to 350 pounds tongue weight and 3,500 pounds towing weight as stated by your vehicle's maximum factory tow rating.

DANGER Never exceed your vehicle's manufacturer's recommended towing capacity which may be a lower rating than this trailer hitch

Unsure of your tow rating? Download our towing app from the app store to find your vehicles tow rating.
www.torkliftcentral.com/app.php